

LAHTI
PRECISION

Ahjokatu 4 A, P.O.B. 22
FI-15801 Lahti, Finland
Tel. +358 3 829 21
Fax +358 3 829 4100
www.lahtiprecision.com

Lahti Precision

Mounting kits for

BC5 load cells 500 kg ... 5000 kg

- The key to high-precision performance in industrial weighing

RGP mounting kits for BC5 load cells are designed to facilitate the assembly of a scale, the mounting of a load cell and the transmitting of the measured force to the load cell.

In conventional load cell assemblies there are often disturbances such as changes of measurements due to loading

or thermal expansion, lateral forces caused by process equipment, vibration etc.

The aim is to eliminate the effects of the disturbances and to secure the accuracy of the weighing results. The durability and the reliability of the scale improve as well.

RGP mounting kits are EU-type-approved for verifiable scales used with WA weight indicators.

RGP mounting kits for BC5 shear beam load cell in the range from 500 kg to 5000 kg

RGP 30A1 and RGP 31A1

Pendulum support mounting kit

- Low profile construction
- Stainless steel
- Self-centering
- Jacking nut
- Vertical constringer
- Horizontal constringer

Thanks to the rolling flat and spherical surfaces in pendulum support construction the scale is free to move all the way to the lateral limiters (measurement P) under eventual bending or thermal expansion of the structures. The construction is self-centering.

By means of the jacking nut in the vertical limiter screw the platform can be locked in the upper position during installation or replacement of the load cell. The screw also acts a limiter to the vertical movement.

A mounting kit with a horizontal constringer is used in situations where the centering force (F_k) of the pendulum support is not sufficient to keep the platform in place. The constringers H30A and H31A receive the horizontal forces which are caused, for example, by the shifting of the load, by the wind and by the rotating motion of a mixer.



Technical specification and dimensions

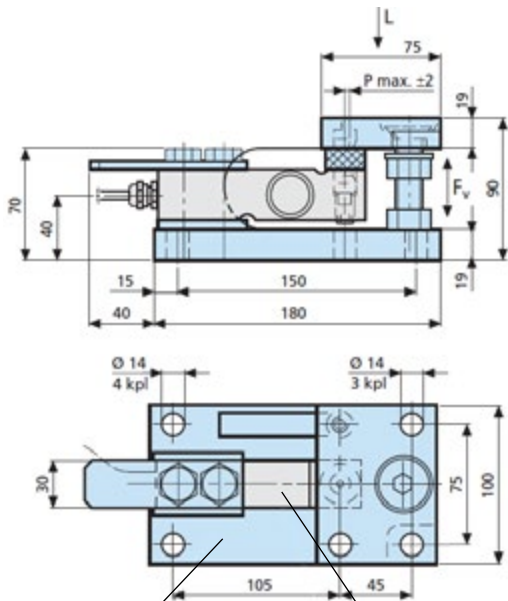

RGP30A1 + 500 kg
BC5 - 1000 kg - C3 - A
2000 kg

Load L 500 kg, 1000 kg, 2000 kg
Centering force F_k 7,7 %/mm (measurement P) of the force acting on the load cell
Lift-off constraining force F_v 6 kN
Total weight 6,0 kg (incl. the load cell)

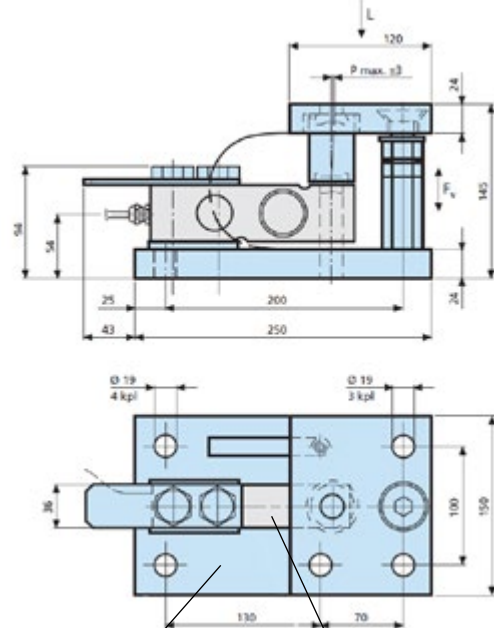

RGP31A1 + BC5 - 5000 kg - C3 - A

Load L 5000 kg
Centering force F_k 5,5%/mm (measurement P) of the force acting on the load cell
Lift-off constraining force F_v 6 kN
Total weight 16,0 kg (incl. the load cell)

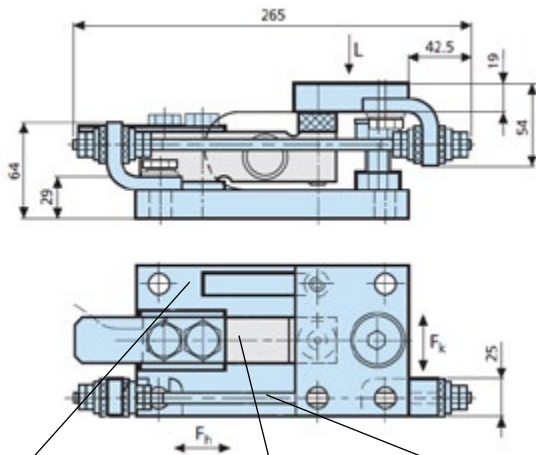

RGP30A1 + 500 kg
BC5 - 1000 kg - C3 - A
2000 kg + H30A

Load L 500 kg, 1000 kg, 2000 kg
Centering force F_k 7,7 %/mm (measurement P) of the force acting on the load cell
Horizontal constraining force F_h 3 kN
Lift-off constraining force F_v 6 kN
Total weight 7,0 kg (incl. the load cell)

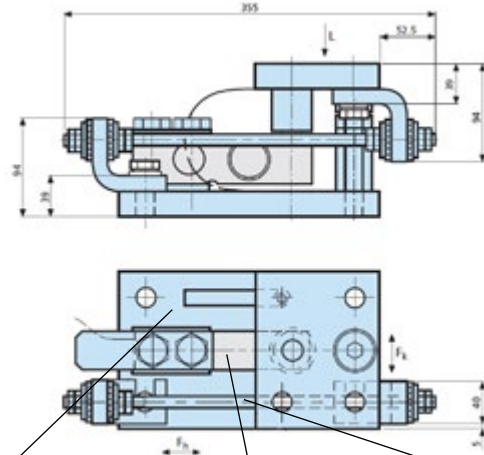

RGP31A + BC5 - 5000 kg - C3 - A + H31A

Load L 5000 kg
Centering force F_k 5,5%/mm (measurement P) of the force acting on the load cell
Horizontal constraining force F_h 7,5kN
Lift-off constraining force F_v 15 kN
Total weight 18,0 kg (incl. the load cell)

RGP 63A and RGP 64A

Elastomer mounting kit

Typical weighing applications for elastomer mounting kits include silos, tanks and mixers and especially facilities with strong disturbance caused by process equipment. The rubber parts absorb shock action and vibration and the self-centering construction offsets any bending of structures under the load, minor mounting errors and thermal expansion. This kit is suited for scales with three load cells.



Technical specification and dimensions

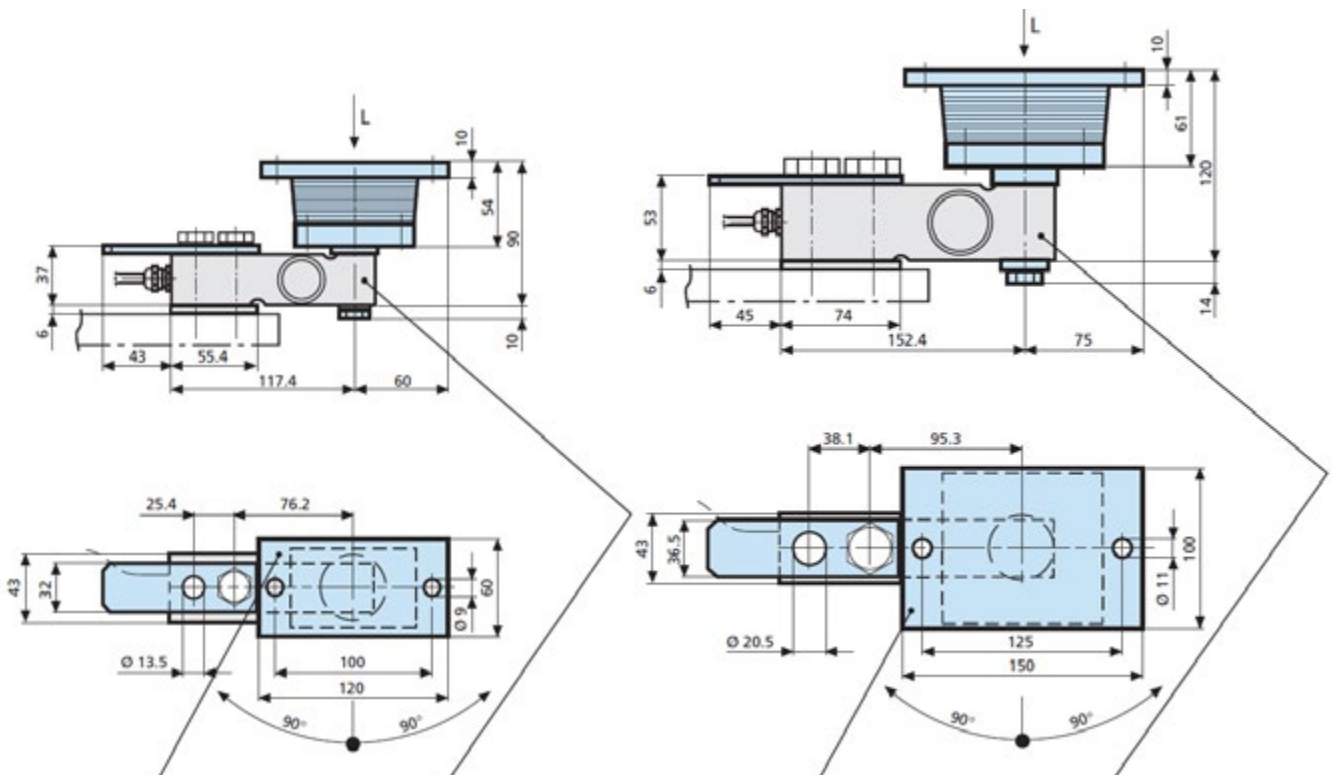

RGP63A	+	500 kg BC5 – 1000 kg – C3 – A 2000 kg
--------	---	---

RGP64A	+	BC5 – 5000 kg – C3 – A
--------	---	------------------------

Load L	500 kg, 1000 kg, 2000 kg
Centering force Fk	380 N/mm (measurement P)
Max permissible lateral movement P max	±5 mm
Total displacement in load direction	0.7 mm/2000 kg
Max permissible lift-off force	5 kN
Total weight	2.6 kg (incl. the load cell)

Load L	5000 kg
Centering force Fk	600 N/mm (measurement P)
Max permissible lateral movement P max	±8 mm
Total displacement in load direction	0.6 mm/5000 kg
Max permissible lift-off force	15 kN
Total weight	6.0 kg (incl. the load cell)